

CHAPTER 2

HITTING A MOVING TARGET FROM A MOVING SHIP

As mentioned in chapter 1 of this training manual, the duties of the Gunner's Mate (Missiles) include the operation and maintenance of guided missile launching systems and associated handling equipment. Your duties as a GMM also include the handling and stowage of guided missiles and guided missile components, replacement and/or maintenance of components, assembly and inspection of missiles, and preparation of missiles for testing.

It would be fairly easy at this point to go right into the subject of guided missile launching systems and let it go at that. However, the launching system is only one part-though a very important part- of the overall shipboard weapons system.

As a GMM, you must know a great deal more about the launching system than merely the operation and maintenance of the mechanisms associated with it. To understand what the mechanisms do, you must know how they fit into the overall weapons system. Thus you must come to understand the basic fire control problem that must be solved to position a missile launcher, and to direct the missile to the target. You must also have a fairly good understanding of the guided missile which you are to launch- especially its propulsion system and warhead.

As a GMM you will be part of a weapons delivery team made up of Radarmen, Fire Control Technicians, and Gunner's Mate Technicians, to name some of the ratings directly involved. In studying this manual, you will come to know something of their jobs as, indeed, they will learn something about yours in their rate training manuals.

You learned some of the basics of fire control in Seaman, Navpers 10120-E, in the chapter on gunnery. With these ideas in mind, let us now take a brief look at some of the basic aspects of the shipboard fire control problems.

DEFINITIONS

A MISSILE may be defined as ANY object capable of being hurled, thrown, projected, or propelled, so as to strike a distant object.

An UNGUIDED MISSILE is a missile which is AIMED - but which CANNOT CONTROL its own trajectory, or flight path. A thrown rock is an example of an unguided missile.

A GUIDED MISSILE is a missile whose trajectory IS CONTROLLED during all or part of its flight, by mechanisms within the missile, or by responding to the missile guidance system.

A ROCKET is a missile which carries a propulsion system that is not dependent on the oxygen in the atmosphere.

Thus, the term MISSILE is a general one. The term ROCKET is specifically limited to missiles propelled by air-independent systems. The distinction between the two terms will become clearer to you later in this course. The important thing to remember now is that a rocket is limited in its meaning.

What is fire control? FIRE CONTROL can be defined as the practical application of exterior and interior ballistics, and the methods and devices used to control missiles, gun projectiles, torpedoes, and other weapons. Another way to put it, in terms of weapons, would be to say that fire control is the process of determining the exact relationship between a weapon and its target, and then using that information to get the weapon to strike or inflict damage on that target.

BASIC FIRE CONTROL PRINCIPLES

We will now cover briefly some basic fire control principles to give you an appreciation of the problems inherent in placing a missile or projectile on the proper trajectory. The principles will be covered in a simple and direct fashion, with no attempt to examine the mathematical aspects of the fire control problem.

(The details of the problem, for the most part, are the responsibility of Fire Control Technicians.)

To illustrate the basic principles of fire control, we will use a simple gunfire control situation. This method of presenting the problem is valid because missile concepts are similar to tried and proven gunnery principles. For example, the first experimental shipboard missile weapon system used modified gunfire control radars and computers to solve the missile fire control problem. Even the launching system used gun power drives to position the launcher. So you can see that there is a close relationship between gunnery and missilery ideas and equipment. As we progress through this chapter, we will point out the similarities and differences between the missile and gunfire control problems.

We will cover gunfire control principles as well as missile fire control concepts. As a GMM you should be familiar with the fire control problem. To advance in rating, a background knowledge of gunfire control is required. So, an early start in the study of gun and missile fire control will better prepare you to meet the professional (technical) qualifications for advancement in rating.

At the beginning of this chapter we distinguished between a guided missile and an unguided missile. Under our previous definitions, it may be said that a football, a bullet from a hunter's rifle, and a 5" projectile, as well as a thrown rock, are unguided missiles.

The problem of delivering a projectile from a gun to a target has been studied for years. Accurate computing devices have been developed to consider many factors before sending a projectile on its way to the target. These factors include target range and bearing, target course and speed, wind direction and speed, movements of the firing platform, and gun ballistics. When these and certain other factors have been determined, the gun may be fired. From that instant on, there is no control over the projectile's trajectory. It is "on its own." Whether or not it hits the target depends on the accuracy of the calculations prior to firing. If the calculations were inaccurate, and the projectile misses, corrections are introduced to bring the next one on the target. This process is repeated, if necessary, until the target is destroyed.

All of the calculations which go into the firing of a missile - whether it be guided or unguided - fall under the general heading of fire

control. The term FIRE CONTROL SYSTEM denotes all of the equipments necessary to achieve this objective.

ELEMENTS OF FIRE CONTROL SYSTEMS

It was stated earlier that a football falls under the category of a missile. Strangely enough, the "launching" of a football requires a fire control system which is in many ways similar to that required for guided missiles or unguided projectiles.

To place a missile - whether it be a football, gun projectile, or a missile - on a trajectory toward a target, there are three essential elements in the fire control system. These are:

1. A means of detecting the target and observing its movements. (Detection and tracking.)
2. A computing system which will accept various inputs and solve the fire control problem.
3. Communications channels which link the detecting equipment and the computing system.

Considering a football as a missile, the passer's eyes serve as the detection system. The passer's brain accepts detection information relayed from the eyes and computes the direction, elevation, and force which must be applied to the ball to place it on a trajectory to the receiver. In computing the proper direction, elevation, and force, the brain takes into consideration such factors as the thrower's motion, the instantaneous direction of the receiver, the direction and speed of the receiver's motion, and the direction and speed of the wind. If all of these are analyzed correctly, the missile launching system (in this case the passer's body) will release the ball with the proper force and in the proper direction to cause a "hit."

In this "human fire control" system, there are two obvious communication links. One of these connects the detection system (the eyes) to the computing system (the brain). The other connects the brain to the launcher - the body, or, more specifically, the arm.

We mentioned earlier that a bullet from a hunter's rifle also falls under the category of a missile. As in the football example, the eye serves as the detecting system, the brain as the computing system, and the body of the hunter and the rifle as the launching system.

CHAPTER 2 - HITTING A MOVING TARGET FROM A MOVING SHIP

Again, if the motions of the target are correctly detected and analyzed, the rifle should ultimately be correctly positioned in train and elevation to bring about a hit.

You will notice that there is one basic difference in the foregoing examples. In the case of the football player, the passer computed direction, elevation, AND force. In the case of the hunter, he computed only direction and elevation. The distinction lies in the fact that the force exerted on the football can be varied at the will of the passer. He may throw the ball 5 yards, or he may throw it 25 yards (or more). In the case of the hunter's rifle, the bullet will leave the rifle at essentially the same velocity (and with the same force) regardless of the distance or direction of the target. From experience, the hunter instinctively allows for this constant initial velocity as he leads his target in bearing and elevation.

By leading his target (a flying bird or running animal) in bearing we mean that the hunter must aim, not at where his target is now, but where he expects it will be when the bullet arrives. He also must aim slightly above the target because gravity pulls the bullet downward.

You will notice that the two key factors in placing a missile initially on its trajectory are bearing and elevation. If we have a rifle, 5" gun, or guided missile launcher initially aimed on the right bearing, and pointed in the proper direction above the horizontal (elevation), the missile will leave its launcher on the desired trajectory.

Earlier we said that the trajectory of a guided missile could be controlled after the missile left its launcher, whereas the trajectory of unguided missiles could not. This is an extremely important consideration, since a change in the target's motion (course and speed) while a projectile is in flight will cause a miss. The guided missile has been designed so that it can alter its trajectory while in flight. Even though the target's speed and direction may change after a guided missile has been launched, the missile guidance system will cause the missile to turn toward the target and yield a hit. The ways in which this is accomplished are described later in this course.

INFLUENCES ON TRAJECTORY BY OUTSIDE FORCES

Once a missile (guided or unguided) is launched, certain outside forces work on it during

its entire flight. We will now look at the effects of some of these forces to give you an idea of some of the factors associated with the fire control problem.

Gravity

The primary natural force acting on a gun projectile or guided missile is gravity. The effects of gravity are felt throughout the entire universe. Everybody in the universe has a gravitational field which works on every other body in the universe. This has been stated mathematically in terms of mass and distance as follows:

Every body in the universe exhibits an attracting force on every other body which is proportional to the product of the mass of the bodies concerned, and inversely proportional to the square of the distance between them.

You have probably heard that the gravitational effects of the moon are considerably less than those on the earth. This is due to the fact that the moon has much less mass than the earth. The effects on the moon's gravity are readily apparent on earth as evidenced by the changing tides. The moon's closeness to the earth permits these effects to be detected. The planet Mars (in our solar system but much farther away than the moon) has a much stronger; gravitational field than the moon, but exhibits no apparent effects on the earth.

Let's come back to earth, and neglect the effects of gravitational fields other than our own. You have heard the old expression that everything that goes up must come down (long since proven dead wrong). For practical purposes, we can consider the expression to be true when the flight of a projectile or guided missile is considered. The earth's gravitational field is pulling on these objects throughout their entire flight.

In 1600, the Italian astronomer Galileo made an interesting observation about the pull of gravity. Legend has it that he dropped several objects of different weight from the Leaning Tower of Pisa, and noted that all of them struck the ground at about the same time. You may readily challenge this statement by persisting that a steel ball will fall faster than a feather. This occurrence is due to the air density rather than the difference in weight of the two objects. If a steel ball and a feather were dropped simultaneously from the same height in a vacuum, they would strike the ground at precisely the same instant. Many experiments have shown that the pull of gravity causes a falling body to accelerate

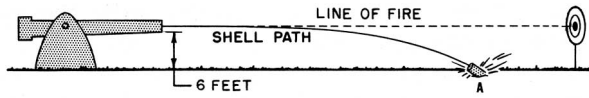

12.1

Figure 2-1.—How gravity affects the trajectory of a projectile.

at the rate of about 32 feet per second (32 ft/sec²). Acceleration is often expressed in terms of g's, one g being equal to an acceleration of 32 ft/sec².

Several simple formulas have been developed which will help you to understand the relationships of acceleration, distance, velocity, and time with respect to a freely falling body. For example, the distance a body will fall in a given amount of time may be computed by the formula:

$$d = 1/2 gt^2$$

where d = distance in feet, t = time in seconds, and g = 32 ft/sec². By using this formula, we

can show that a freely falling object will fall 16 feet the first second, i.e.:

$$d - (1/2) (32 \text{ ft/sec}^2) (1 \text{ sec})^2 = 16 \text{ ft}$$

During the first two seconds, the body will fall (1/2) (32 ft/sec²) (2 sec²)2 = (32) (4) ÷ 2 = 64 ft.

To determine the velocity at any instant of fall, you can use the formula:

$$v = v_1 +gt$$

where v₁ is the initial velocity, g is 32 ft/sec², and t is the time in seconds. For example, at the instant of release, v₁ will equal zero. Therefore, the body would fall at the rate of 32 ft/sec at the end of the first second, since v = 0 + (32 ft/sec²) (1 sec). At the end of 5 seconds, the same body would be falling at the rate of 160 ft/sec, i.e.:

$$v = 0 + (32 \text{ ft/sec}^2) (5 \text{ sec}) = 160 \text{ ft/sec}$$

Now let's look at figure 2-1 to see how gravity affects the trajectory of a projectile. In this figure, the gun is pointed directly at the target. The line along the axis of the bore, which is extended from the end of the barrel, is called the LINE OF DEPARTURE or the LINE OF FIRE (LOF).

At the instant the projectile leaves the muzzle and is free from the constraining effects of the barrel, the pull of gravity begins to affect it. The projectile immediately starts to drop, and falls substantially short of the target. It

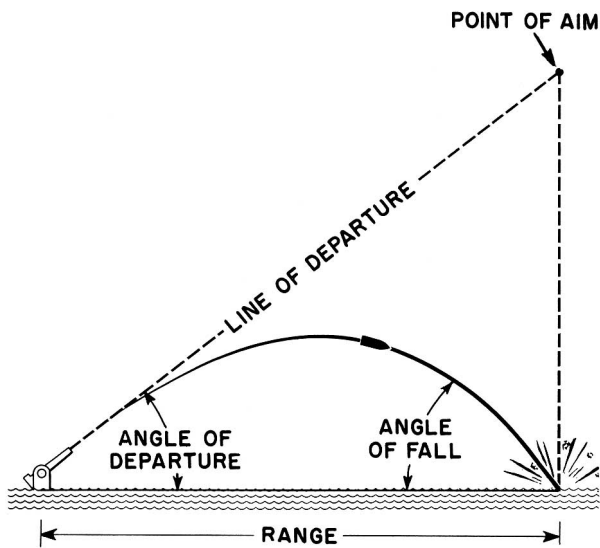

12.2

Figure 2-2.—Increased elevation produces increased range.

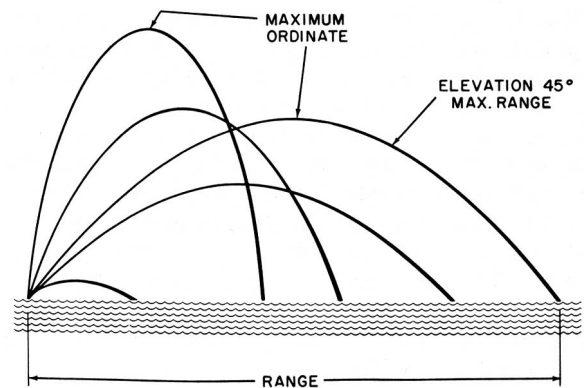

12.4

Figure 2-3.—Parabolic trajectories.

is obvious from the figure that the gun must be elevated to hit the target. Suppose the gun is elevated by the amount shown in figure 2-2. Note that the projectile again drops with respect to the line of departure, even though it is going up with respect to the horizontal. The angle between the horizontal and the line of departure is called the **ANGLE OF DEPARTURE**. The distance from the gun to the target is called the **RANGE**.

The two primary forces, neglecting air resistance, which work on a projectile in flight—gravity and the force imparted by the propellant charge—cause an unguided projectile to follow anyone of an infinite number of parabolic trajectories such as those shown in figure 2-3. From this figure, you can see that a gun elevation of 45° produces maximum range for a projectile. At gun elevations greater than 45° , the maximum ordinate (highest point on the trajectory) will be higher, but the range will be less. At elevations less than 45° , both the maximum ordinate and the range will be less.

The gun elevation necessary to compensate for the shape of the trajectory is called **SUPER-ELEVATION**. Thus, superelevation is the angle through which the gun in figure 2-1 would have to be elevated to hit the target. Superelevation is calculated for various types of projectiles by tests and observations at the Naval Weapons Laboratory, Dahlgren, Va., and is a factor in the elevation computations of the fire control problem.

Looking again at figure 2-1, an interesting point to be observed is that the fired projectile would strike the ground at point A in exactly the same amount of time that it would strike the ground if it were merely dropped from the end of the gun barrel. In both cases, the projectile would be a maximum of 6 feet from the ground. The constant acceleration of gravity would yield the same time of flight in either case. To increase projectile time of flight, the gun must be elevated above the horizontal and, neglecting air resistance, the angle of departure will equal the angle of fall (fig. 2-2). The initial (muzzle) velocity of the projectile will be equal to the striking velocity, and the time that it takes the projectile to proceed to its maximum ordinate will equal the time that it will take it to fall from its maximum ordinate to the height of the muzzle.

The force of gravity will affect a missile's trajectory just as it affects the trajectory of a gun projectile. To correct the gravity error, you just elevate the launcher the proper amount.

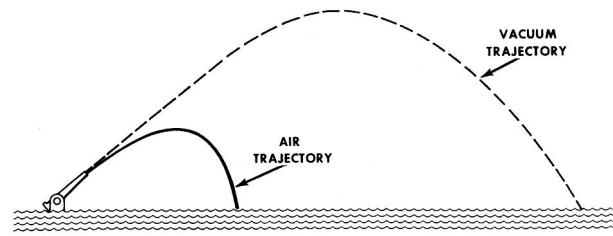

12.4

Figure 2-4.— Effects of air density on ideal trajectory.

Effects of Air Density

Up to this point, the effects of air density on a projectile's flight path have been ignored. However, in actual practice, we must account for the density of the air, which causes significant changes in the ideal trajectories just discussed. Figure 2-4 shows how the air density might affect an ideal trajectory of a projectile fired in a vacuum. The effect of air is to set up a resistance against any body passing through it. The resistance causes both a loss in speed and a loss in range.

A peculiar thing about air resistance is that it increases rapidly as the speed of the body increases. Roughly, when the speed doubles, the retardation of the projectile becomes more than four times as great. Thus, if a projectile traveling at 1000 ft/sec were retarded 100 ft/sec every second, a projectile traveling 2000 ft/sec might be slowed as much as 400 ft/sec every second. Just as an object passing through water creates waves that retard its movement, an object passing through air creates air waves. The effects of shape, size, speed, and angle of attack of an object upon air movements will be discussed in the next chapter with regard to effect on missile flight.

With a little thought you can see what air resistance does to the shape of the ideal trajectory. The longer the projectile travels through the air, the slower it goes. Shortening of the trajectory will be more noticeable at the far end. The high point of the trajectory will not be at the middle as it would be in a vacuum, but will be nearer the point of impact than it is to the gun.

The way to compensate for air resistance is to increase range by additional elevation. In figure 2-5, the dotted line shows the trajectory of a projectile in a vacuum. Notice how much

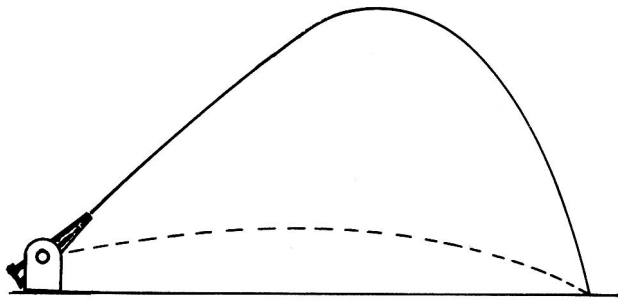

12.5
Figure 2-5.—The way to compensate for air resistance.

additional elevation the gun must have to fire the projectile the same range through air (solid line trajectory).

It would be a very simple matter to compensate for air density in the gunfire control problem if the density were constant in all localities. Actually, air density depends in great measure on temperature and barometric pressure. Needless to say, these two factors are continuously varying. Moreover, air density decreases with altitude along the trajectory, as does temperature.

The shape of the projectile also makes a difference. Obviously, the bigger around the projectile is, the more air will push against it. A pointed nose makes it easier for the projectile to push its way through the air, and thus reduces resistance. Boat-tailing, or tapering, the after end of the projectile reduces the drag

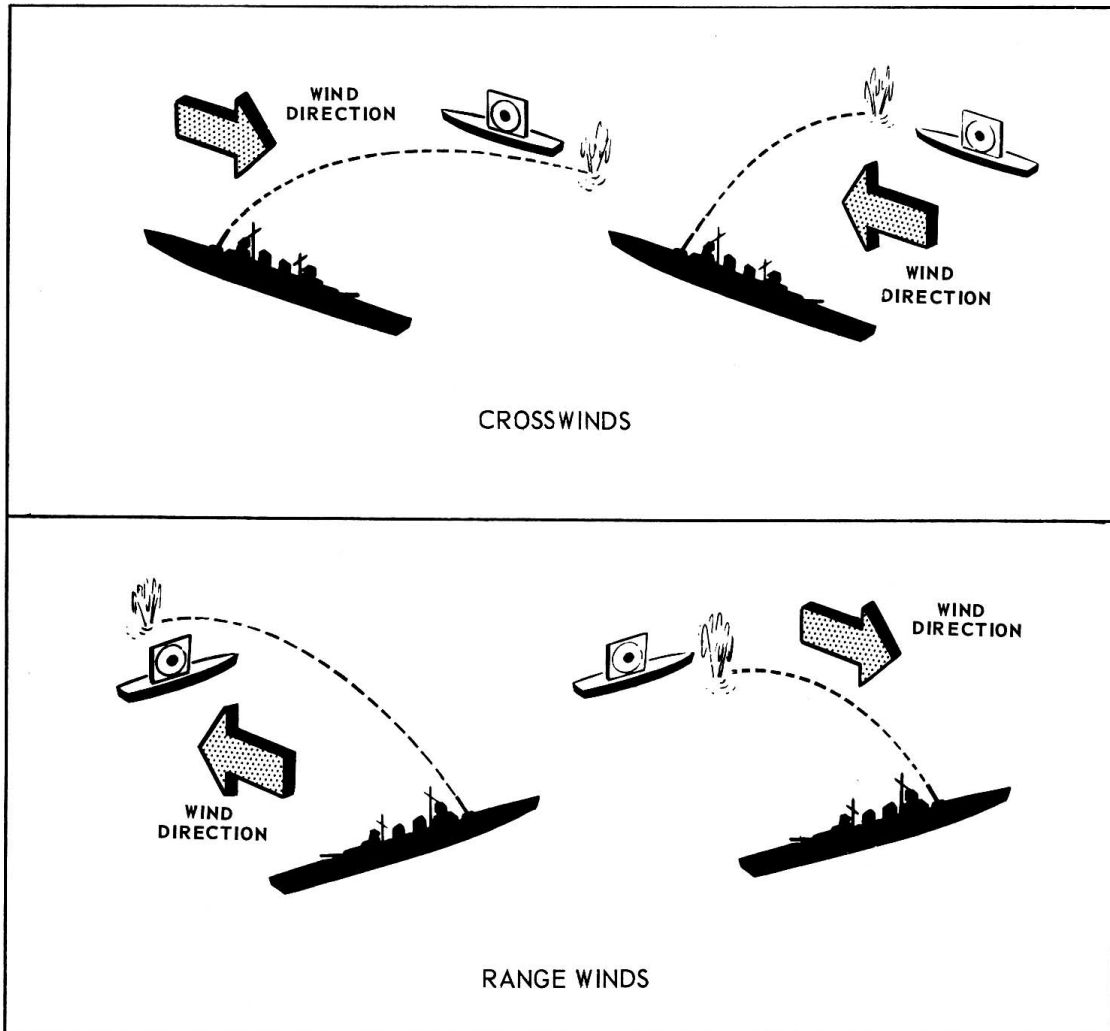

12.8
Figure 2-6.—Wind effects on projectile.

CHAPTER 2 - HITTING A MOVING TARGET FROM A MOVING SHIP

resulting from air turbulence behind the projectile, and this also reduces resistance.

Guided missiles, like any physical body, are affected by air density. To make their passage through air easier, guided missiles are streamlined. They also contain instruments that measure air density. At high altitudes, where the air is thin, the control surfaces of a missile must deflect more to turn a missile a given amount. The air density measuring device provides a signal to the missile's control system, telling it to increase or decrease the amount of rudder required for a particular maneuver.

Wind

Another natural force which works on a guided missile or projectile is wind. You will remember that the football player takes the wind into account before throwing a forward pass. If you have ever played football on a windy day, you will remember that a well-aimed forward pass may have curved to the right or left, or fallen short of or beyond the point where you wanted it to land.

Wind has exactly the same effect on a projectile in flight. The effect of wind can be seen in figure 2-6. If the wind blows from the left, the projectile will turn to the right, and vice versa. If the projectile is headed into the wind, its range will be decreased. If it travels with the wind, the range will be increased. You can see that effects of wind must be considered in the solution of the fire control problem.

A wind that is blowing at right angles to the projectile's line of fire is a "crosswind." If it is blowing along the LOF, either with' or against the projectile, it is called a "range wind."

If the wind is blowing along the LOF against the projectile, the projectile will fall short of the target. To compensate for this, we must elevate the gun to increase the range of the projectile. If the wind is blowing with the projectile, the projectile will land beyond the target. To compensate for this, we must depress (lower) the gun or launcher to decrease the range.

If the wind is blowing from the right (at 90° to the LOF), the projectile will land to the left of the target. To compensate for this, we must train the gun or launcher to the right. If the wind is blowing from the left at 90° to the LOF, the projectile will land to the right of the target. To compensate for this we must train the gun or launcher to the left. The corrections for both types of wind are shown in figure 2-7.

The examples given here are special cases. Obviously, wind does not always blow directly at right angles to the line of fire or directly along it. If the wind were cooperative enough

to perform in this manner, it would be a relatively simple matter to compute the wind corrections. In most cases, the wind will be at some other angle to the LOF. To correct for wind, it is necessary to resolve the true wind into components in line with and perpendicular to the LOF. When this is done, each component can be treated individually and the proper gun setting or launcher adjustments made.

Immediately after firing, a projectile is traveling at such a high speed that the wind does not affect its flight very much. As the projectile slows down during its flight, the wind effects become more noticeable. Hence, the longer a projectile remains in flight, the more its trajectory will be altered by the wind, so that the wind deflection increases with range. While the effects of wind on missile trajectory are modified by the powered flight, they must be included in the calculations. Wind effects can be especially noticeable on long-range missiles, such as intercontinental ballistic missiles. The computations are further complicated by the decreasing mass of the rocket or missile as the fuel burns up.

Two other factors which affect the trajectory are wind speed and projectile size. Obviously, the greater the wind velocity, the greater the effect on the projectile. At the same initial velocity, a heavy projectile would be affected less by wind than would a light one.

Corrections for the effects of wind are only approximate, because wind speed and direction are usually different at various levels. For instance, the wind might be blowing from the north on the surface of the ocean, and from the south at an altitude of 6000 feet. In such a case, a projectile's trajectory would be affected differently as it is acted on by the winds at various altitudes.

Wind conditions at different altitudes are sometimes determined by observations from airplanes or by observing the movements of small balloons. If it is found that a projectile's trajectory will take it through winds which move in different directions, a "weighted ballistic wind" may be used to compute gunsetting or launcher corrections.

If the projectile's trajectory is low, and passes through winds of one direction only, surface wind is used to compute corrections.

In the upper air, winds blow up and down as well as horizontally. These vertical winds can lift the projectile or hold it down, and thus lengthen or shorten the range. Because these winds are extremely difficult to measure, and

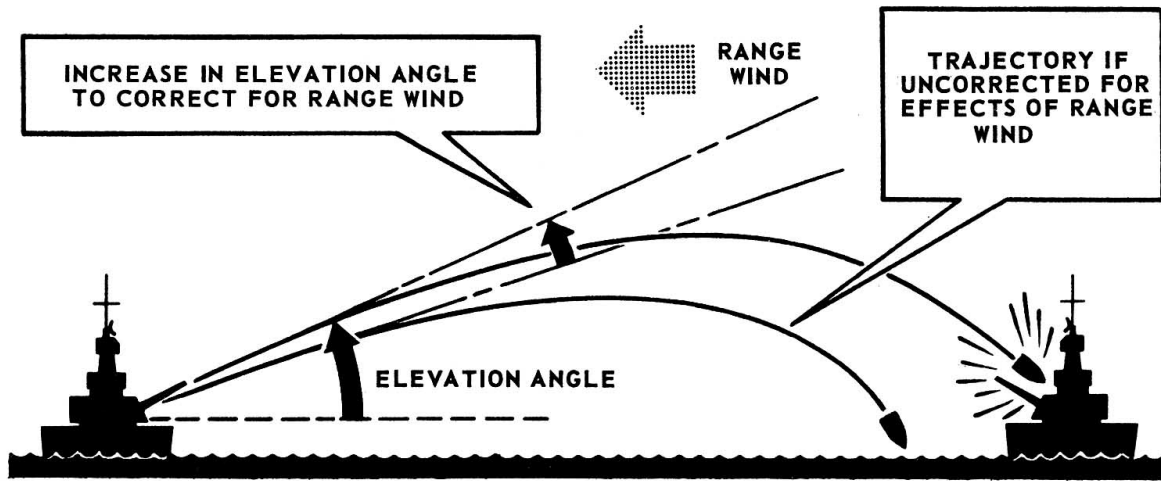

CORRECTING FOR THE EFFECTS OF RANGE WIND

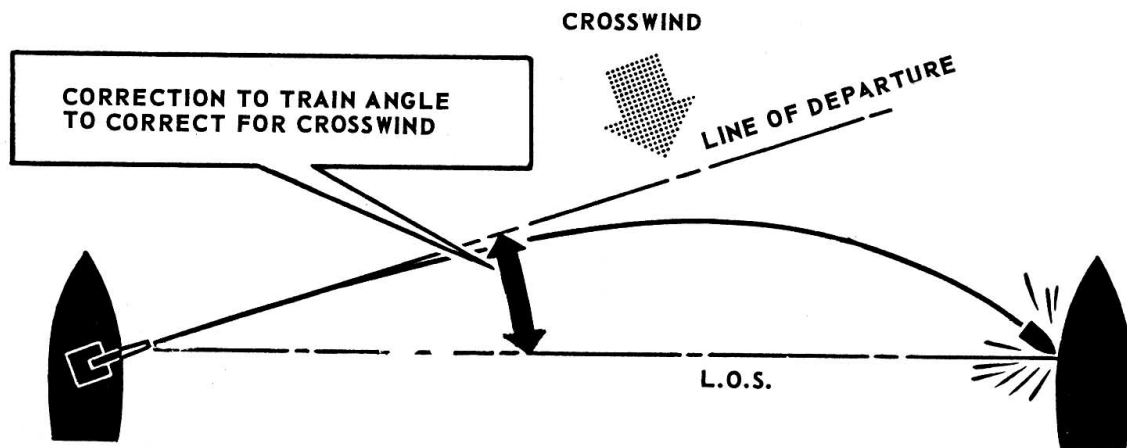

CORRECTING FOR THE EFFECTS OF CROSSWIND

12.9

Figure 2-7.—Correcting for wind.

actually have little practical effect, they are not considered in fire control computations.

The guided missiles that concern you are boosted into the air. This boost portion of flight is very short, about 5 seconds. During this time the missile is essentially an unguided projectile. Wind, gravity, and air density affect it just as they would a gun projectile. After the boost period is over, the missile enters its guided phase of flight. Even then, these external forces are still at work. But they are corrected for by control surface (wing or tail) movements. To correct for wind and gravity effects during the boost phase, corrections are included in launcher elevation and train orders. Air density is taken care of by booster thrust design.

Coriolis Effect

The Coriolis effect (named after the French scientist Coriolis) also has an effect on the trajectory of a missile or projectile. Although not compensated for in all fire control problems, the Coriolis effect is worth discussing since it becomes important especially with respect to long range gunfire and missiles.

The effect is based on the fact that the different points on the earth's surface have different velocities around the axis of the earth. In figure 2-8 the object at the Equator has a velocity of about 1000 miles per hour around the

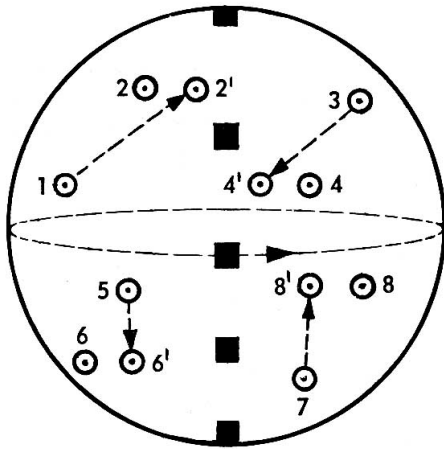

33.136

Figure 2-8.— Coriolis effects.

earth's axis. The two objects between the Equator and the poles will have a considerably smaller velocity. The objects at the poles will have zero velocity.

If we fire a projectile from point 1 toward point 2 and do not correct for the Coriolis effect, it will be deflected to the right of the target, as shown by the dotted lines. In this case, the velocity of the launching point is greater than that of the target. The launching point component of velocity will cause the projectile's deflection to the right, and cause it to strike at point 2'.

Now assume that we fire from point 3 to point 4, again failing to correct for the Coriolis effect. The projectile will again be deflected to the right of the target, landing at point 4'. In this case, the launch point has a smaller velocity than the target point.

From the foregoing, we can say that if the Coriolis effect is not corrected for, a projectile will be deflected to the right of the target in the Northern Hemisphere due to the difference in velocity of points at different latitudes.

In the Southern Hemisphere, the effect is reversed; that is, a projectile is deflected to its left. This can be seen when firing from point 5 toward point 6 in the illustration. The higher velocity at point 5 (relative to point 6) will cause the projectile to be deflected to its left, landing at point 6'. If we fire in a northerly direction in the Southern Hemisphere, the projectile will still be deflected to its left as shown by points 7, 8, and 8'.

Therefore, we can say that if the Coriolis effect is not corrected for, a projectile will always be deflected to the left of the target in the Southern Hemisphere.

The curvature of the earth, too, is of little significance in short-range firing, but must be included in the computations for long-range shots.

Stabilization

Another very important factor which must be taken into consideration is solving the shipboard fire control problem is stabilization. In figure 2-9A, we show a ship whose deck plane is horizontal. In this case, the target elevation and bearing noted by the detecting equipment is referenced correctly to the horizontal plane. Now look at figure 2-9B. In this illustration you can see that the pitch and roll of the deck causes the values of target elevation to vary, since they are measured from the tilting deck plane. Since a ship is continuously rolling and pitching, the amounts by which the deck plane varies from the horizontal plane must be continuously measured and compensated for in the solution to the fire control problem. (Although not shown, bearing will also vary because of the roll and pitch.)

Stabilization information consists of two quantities -level and crosslevel. Level is the angle between the deck plane and the horizontal plane, measured in a vertical plane through the line of sight. CROSSLEVEL is the angle between the deck plane and the horizontal plane measured in a plane at right angles to the vertical plane through the line of sight at right angles to the deck. Figure 2-9C, D, and E show the relationships of level and crosslevel to the planes involved. Level and crosslevel angles are continuously measured by the ship's STABLE ELEMENT, and are a significant factor in the correct solution to the fire control problem.

Trunnion Tilt

Guns and missile launchers are mounted between trunnions, which tilt as the deck rolls and pitches. Trunnion tilt corrections are corrections necessary to keep the guns or launchers pointing along the line of fire despite the tilting of the trunnions. In figure 2-10, you can see that a tilting deck would cause a miss if the tilt were not compensated for. Thus, trunnion tilt must also be measured continuously and corrected for in the gun or launcher train and elevation orders.

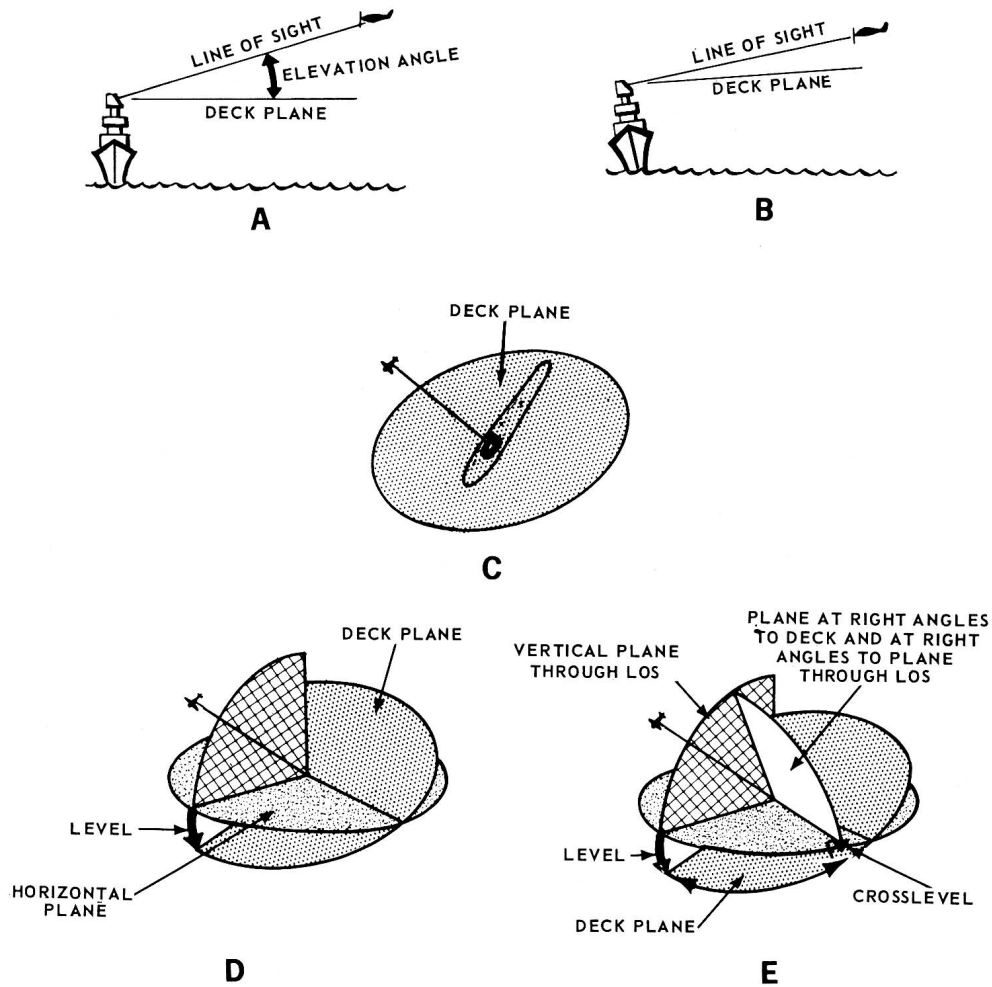

83.1

Figure 2-9.— The effect of ship roll and pitch on the fire control problem; A. Ship's deck horizontal; B. Roll and pitch tilt the deck angle; C. Plane of reference; D. Angle of level; E. Angle of cross-level.

Parallax

Another factor to be considered in the fire control problem is parallax. In figure 2-11, the detecting equipment is trained on a target on the port beam. You can see that only one of the guns would hit the target if all were trained on the port beam.

The problem of parallax stems from the fact that the guns and launchers are displaced from the tracking (fire control director) equipment. Thus, the line of sight between the tracking

equipment and the target does not coincide with the line of sight between the guns and launchers and the target.

The director must correct its orders for LOF so lines of sight from the guns and launchers in different parts of the ship will all converge on the target. The farther the gun or launcher is from the director, the greater the horizontal parallax correction will be. Figure 2-11B shows how the guns are brought to bear on the target when the parallax has been compensated for. Figure 2-11C shows that an elevation correction is also necessary since the gun and tracking equipment are

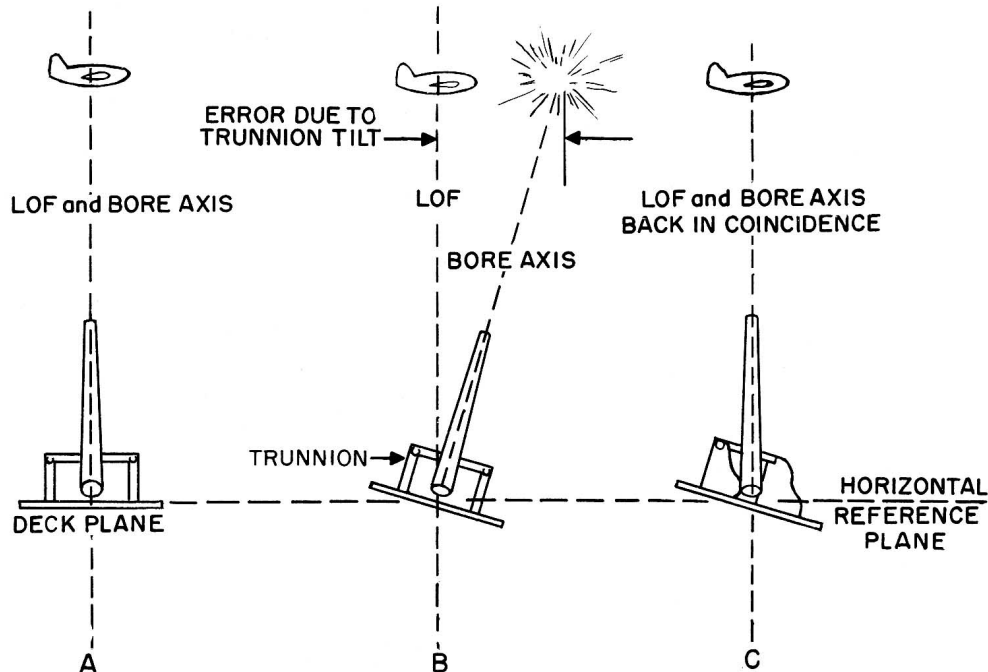

55.251

Figure 2-10.—Trunnion tilt and fire control: A. Deck level — a hit without corrections; B. Trunnion tilt not compensated for — projectile misses; C. Correction made for trunnion tilt — projectile hits.

at different heights. Actually, the parallax corrections are relatively small angles (greatly exaggerated in the figures) which change the gun orders only slightly. Moreover, parallax may be corrected for with little difficulty, since the guns and launchers are at fixed distances from the tracking equipment on any given ship.

It is important to mention that parallax effects become more significant at short ranges such as those shown in the figures than they would be at long ranges. At extremely long ranges, the effects become negligible.

EFFECTS OF INTERIOR FORCES

Interior ballistics is the study of what happens while the projectile travels through the bore of the gun from the instant of firing. Since missiles are fired from launchers and do not pass through a bore, you can readily see that some of the factors will not affect the trajectories of missiles. Both gun barrel and launcher give the initial direction to the projectile or missile.

Initial Velocity

The "send-off", of a projectile or missile makes a big difference in how far and how fast it goes. In the old days when each gun was hand loaded by tamping in a measured quantity of gunpowder, wadding, and shot, the result was not predictable. With the manufacture of ammunition rounds in factories according to precise standards, it became possible to prepare range tables for all sizes and types of ammunition. Until the more recent replacement by automatic computations, range tables were consulted in all gunnery computations. While Navy officers still had to learn how to figure where their shots would land, the range tables were a convenient source of prefigured data for every type of ammunition in the Navy.

The initial velocity for missiles is furnished by the booster. Its size, weight, and type of propellant determine the initial velocity of the missile.

Drift

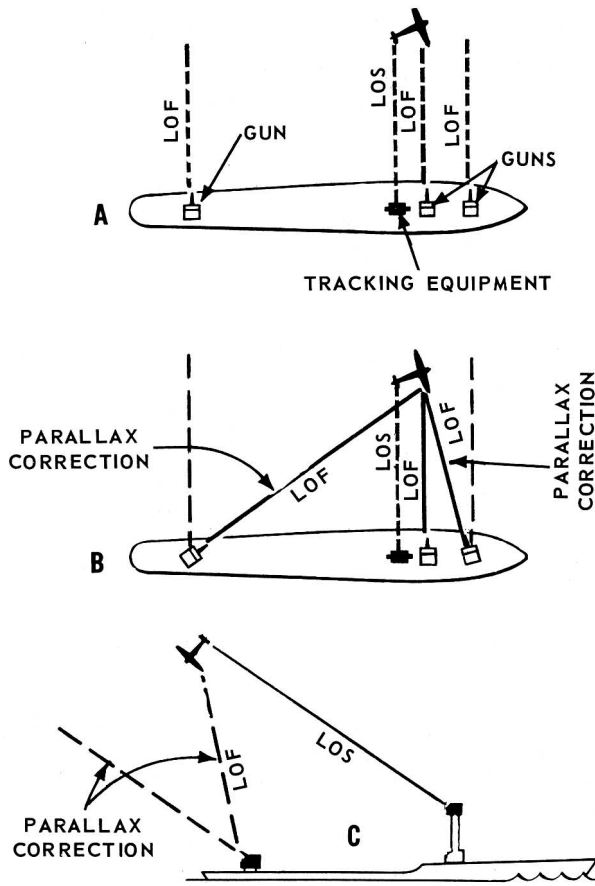

83.3

Figure 2-11.—Parallax correction: A. Cause of parallax problem; B. Correction of horizontal parallax; C. Correction of vertical parallax.

Condition of Propellant

With composition, size, shape, quantity, configuration, and containment of the propellant all determined with exactitude before you receive the projectiles or missiles, what influence does the work of Gunner's Mates have in initial velocity? The condition of the propellant at the time of use can have great influence. One of these conditions is the temperature. Another condition is humidity. Temperature and humidity of the missile storage spaces must be carefully regulated. A higher temperature results in greater energy release, and therefore the booster propellant "burns up" faster.

Another factor that affects the trajectory of a projectile is drift. Drift is not a simple effect; it's the product of the interaction of three other factors - namely, the clockwise spin of the projectile, the force of gravity, and air resistance. As the spinning projectile moves through the air, it tends to point slightly above the trajectory, and the air pressure on its underside develops a thrust that tends to tumble the projectile end over end. But like any other rapidly spinning mass, the projectile reacts to a thrust tending to displace its axis of spin by precessing gyroscopically. (You'll learn more about gyroscopic action as you learn more about fire control, so we won't go into detail about it at this point.) In this case, the precessing movement is a slow turn to the right. The result is that the projectile's course is deflected to the right-relatively slowly at first, but more and more as the trajectory lengthens.

The direction of drift depends entirely on the direction of rotation of the projectile. Every rifled weapon in the Navy (with one exception - the .45 caliber pistol) causes projectile spin to the right (that is, clockwise as viewed from the projectile base), and drift to the right.

Drift increases with range, but it is completely independent of wind. Since missiles are not fired from rifled barrels, this type of deflection does not occur.

WHY WE NEED FIRE CONTROL INSTRUMENTS

Picture yourself on the deck of a modern warship, charged with the responsibility of directing the ship's gunfire. The target is visible on the horizon and it is up to you to tell the gunner how he must elevate and train his guns in order to score a hit on the enemy. You are familiar with the corrections that must be applied and you know how they are calculated. So, first you determine range and bearing 'by eye'; then you must correct for drift, wind, air resistance, earth's curvature, and rotation of the earth. You must determine the target's course and speed, predict its future position, allow for own ship's motion, predict future range and deflection, and correct for level and crosslevel. You work rapidly and after a half-hour or so, you come up with the answer. By that time the target has disappeared or has blown you out of the water.

The solution of the modern fire control problem cannot be reached rapidly nor accurately enough without the help of various fire control

CHAPTER 2 - HITTING A MOVING TARGET FROM A MOVING SHIP

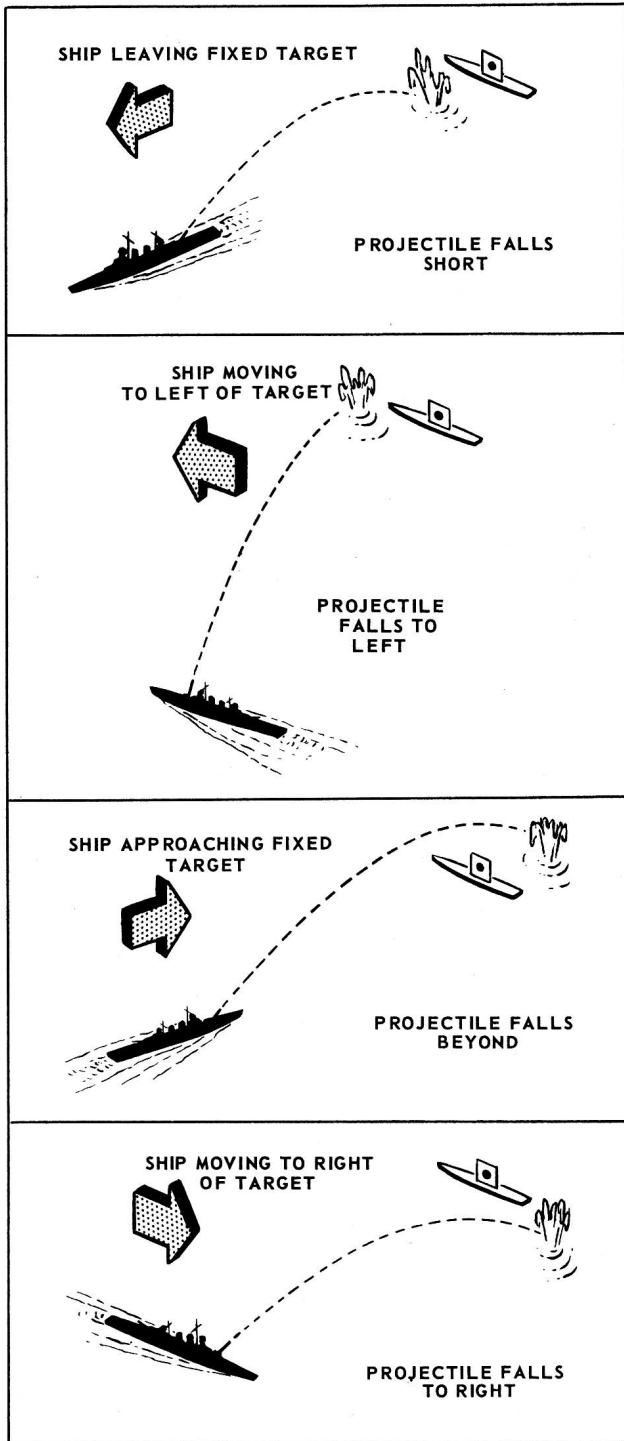

12.15
Figure 2-12.— Errors in gunfire caused by movement of own ship when target is fixed.

equipments and related equipment. A hit or miss method is intolerable; modern fire control instruments are essential to get the most out of our expensive, modern weapons. Gunner's Mates need to know the basic principles of fire control.

HITTING A MOVING TARGET FROM A MOVING SHIP

From what has been discussed to this point, you know that we must offset a gun or launcher from the line of sight (LOS) between the tracking equipment and the target to compensate for such factors as superelevation, air density (gunfire only), wind, stabilization, and parallax. Important as these factors are in the ultimate correct solution to the fire control problem, they must be accurately related to the movements of own ship and target if we are to come anywhere close to getting a hit.

Thus far, we have been discussing various factors affecting the fire control problem as though the target were standing still. In the vast majority of cases, the target is moving- either on the surface of the sea, or in the air over it. The movement of the target with respect to the firing ship is by far the most important factor in the computation of the fire control solution and the correct positioning of the guns and launchers.

In any fire control problem involving a moving target, the target must be led - just as the duck hunter leads the duck or the passer in a football game leads his receiver running down the field. For a surface ship target, the problem is relatively simple. The first thing to be considered is the motion of own ship. Figure 2-12 shows how the motions of the firing ship will cause errors in the projectile trajectory if not compensated for. In the first part of the figure, the firing ship is headed away from the stationary target at, say, 5 knots. With own ship's course and speed not compensated for, the projectile falls short. If the firing ship's speed were greater in the same direction, the projectile would fall short by an even greater amount. The next three parts of the figure show that different courses of the firing ship with relation to the target will produce similar errors. By taking own ship's course and speed into consideration in the solution of the problem, these effects are compensated for and the errors are nullified.

Now, let us see what happens when the target starts moving. Figure 2-13 shows a situation in which the firing ship and target ship are both moving. You can see that if we fired at the instantaneous position of the target - that is, along the line of sight - the target would have moved to a new location while the projectile was in flight. We therefore must predict a future position of the target which will permit the gun to be offset from the line of sight by the amount necessary to cause a hit. To do this we must first know the target's course and speed, as well as our own.

APPLICATION OF FIRE CONTROL PRINCIPLES

Fire control systems vary on different ships and for different gun and weapon systems. In all modern systems, computations of the effects of the various forces, internal and external, that affect the trajectory of projectiles and missiles, are made automatically.

SOLVING THE SURFACE PROBLEM

Earlier we said that a detection system, a computing system, and communications links were the elements of a fire control system. Figure 2-14 shows how these elements are linked together with a gun and a launcher.

For the detection system we use a radar set. The radar uses the transmission and reception of electromagnetic radio frequency energy to provide us with information as to the target's precise location with respect to our own ship at any given time. This information is automatically transmitted to the computer in the form of target ranges and bearings. The computer automatically compares the range and bearing information with elapsed time and continuously generates target course and speed.

The computer also accepts course and speed information automatically from own ship's gyro and pitometer log, certain inputs (such as initial velocity), air density, wind speed and direction, level and crosslevel signal information from the ship's stable elements, trunnion tilt, and parallax corrections, in some cases Coriolis effect, and other inputs which have a lesser bearing on the problem. In addition, it automatically compensates for superelevation (defined earlier in this chapter). (The use of a pitometer log in measuring own ship's speed is described and illustrated in Basic Machines, NavPers 10624-A, page 61.)

The computer continuously analyzes all of this information (some of which may be set in by hand, depending on the system involved), and comes up with a continuous solution to the problem. This solution consists primarily of two continuously generated quantities:

1. The angle by which the line of fire must be offset from the line of sight in bearing. This angle is called sight deflection.
2. The angle which the line of fire must be offset from the line of sight in elevation. This angle is called sight angle.

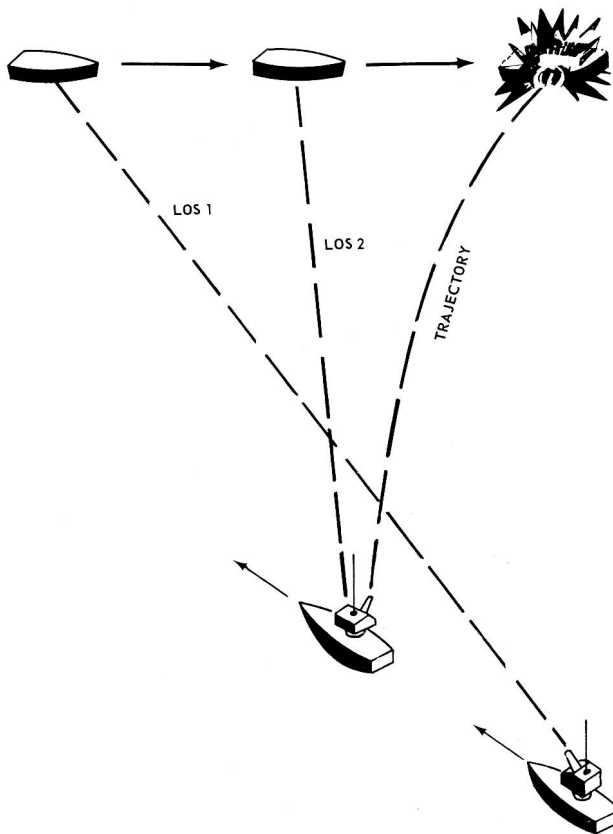

83.4

Figure 2-13.— Movement of target and own ship affect line of sight.

CHAPTER 2 - HITTING A MOVING TARGET FROM A MOVING SHIP

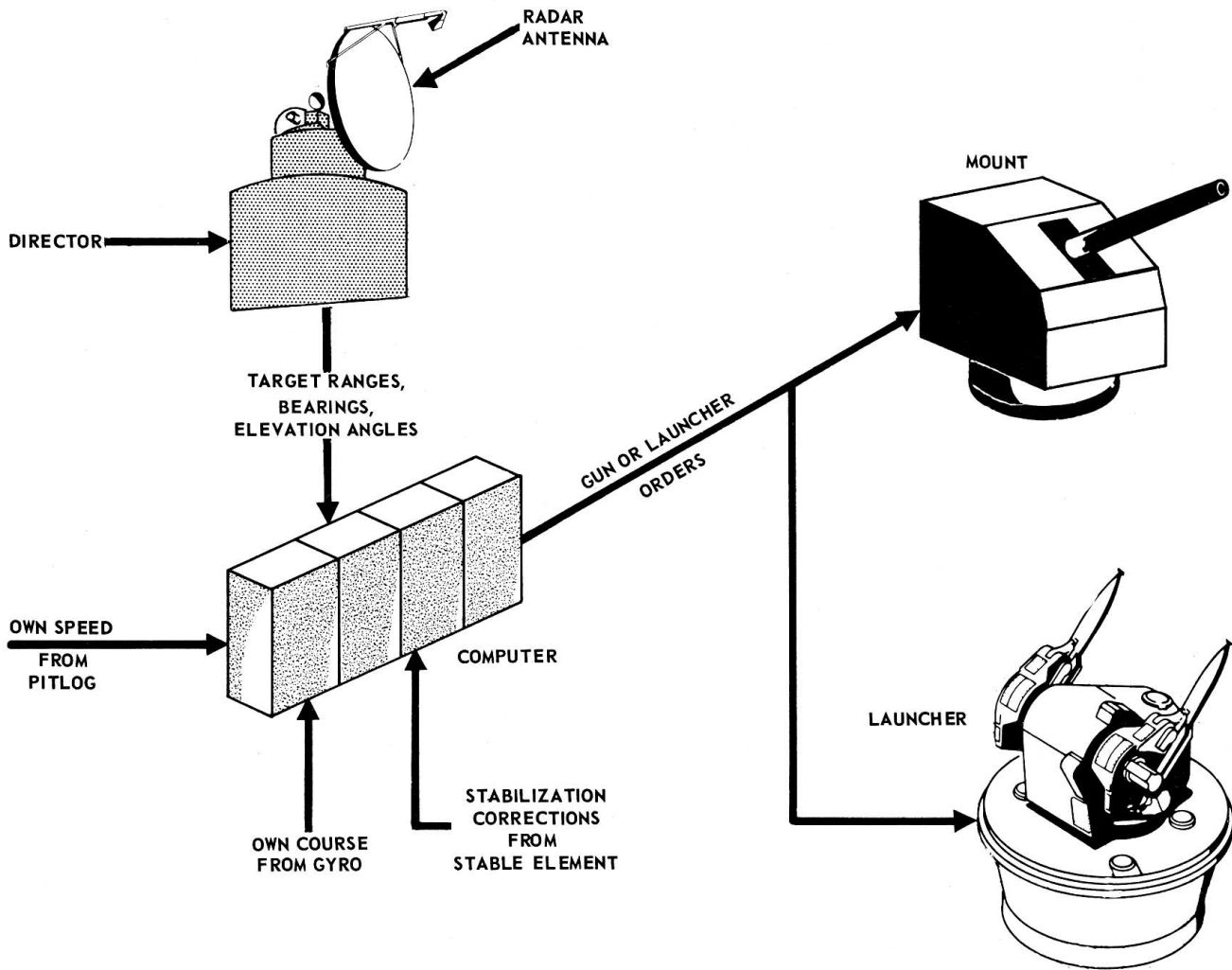

83.5

Figure 2-14.— Elements of simplified fire control system.

These quantities (fig. 2-15) are generated continuously and automatically. After they are corrected for roll and pitch, they arrive as gun train and elevation orders at the mount power drives, thus causing the gun barrel to continuously lead the target by the amount necessary to yield a proper trajectory.

SOLVING THE ANTI-AIRCRAFT PROBLEM

The gun anti-aircraft problem is somewhat more complicated than the surface problem because target altitude is involved, and also because of the greater speed of air targets.

Figure 2-16 shows an aircraft approaching a ship. Again, the line of sight represents the instantaneous direction and range from the detecting equipment to the target. As with the

surface problem, firing along the line of sight would be to no avail, since the target would have passed to a new position during the time of flight of the projectile. In computing the air target's course and speed, the target elevation angles are continuously measured by the ship's detecting equipment in addition to the bearings and ranges. As in the case of the surface target, own ship motions and target motions (in this case bearings, ranges, and elevation angles) are used to position the gun or launcher to lead the target by the correct amount.

It is worthwhile mentioning here that any changes in target course and speed (surface or air problem) are quickly recognized by the detection equipment, and the new information fed to the computer, which immediately corrects the solution and the gun orders. The original predicted target position is continuously

and automatically revised as information is received by the computers and the corrections are sent to the gun or launcher.

The line of sight to the moving air target in figure 2-16 assumes that the ship's deck remains horizontal, which is rarely the case. Corrections for roll and pitch of the ship are included in the computation for the correct line of fire to be used in order to hit the target where it will be at the time calculated.

Figure 2-17B shows that sight angle for the air target includes allowance for target elevation angles. Compare it with figure 2-17 A. The line of sight establishes the relationship between the target and the gun. Sight angle and sight deflection are measured from the line of sight to the line of fire. However, for an air target (fig. 2-17B), the line of sight is not in the horizontal plane but in the slant plane. The angles are measured from the slant plane.

THE BEAM-RIDER MISSILE AA
FIRE CONTROL PROBLEM

So far in this chapter, we have emphasized the gunfire control problem. Now let's change our thinking a little and look at the fire control problem presented to one type of beam-rider missile. We won't have to shift our mental gears very much because, as you will see, there is very little difference between the two problems. In the gun problem we pointed a gun at an airplane with enough lead angle to compensate for target motion during projectile flight and to correct for the effects of wind, drift, gravity, and initial velocity. Basically, the only difference

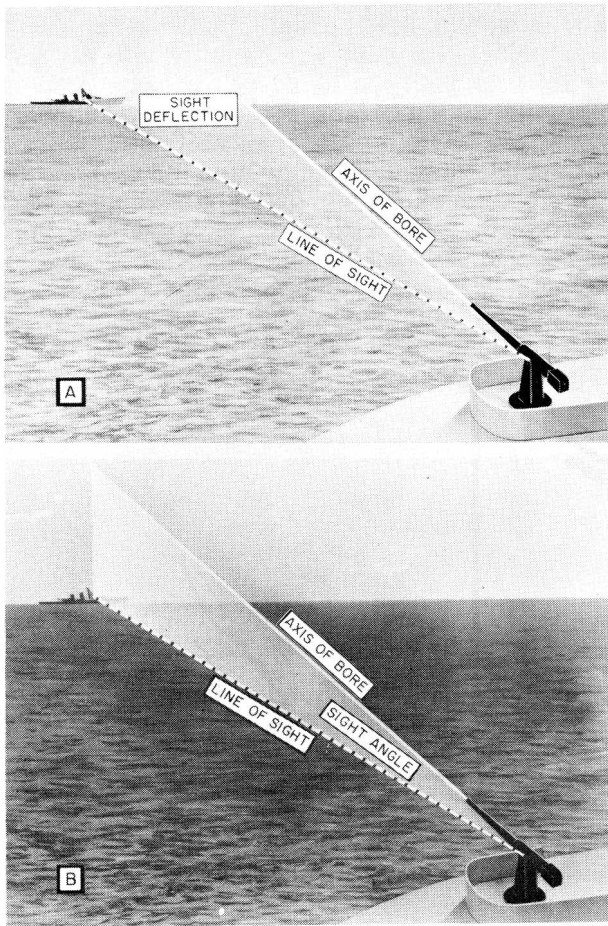

84.198

Figure 2-15.—Offset of gun from line of sight:
A. Sight deflection; B. Sight angle.

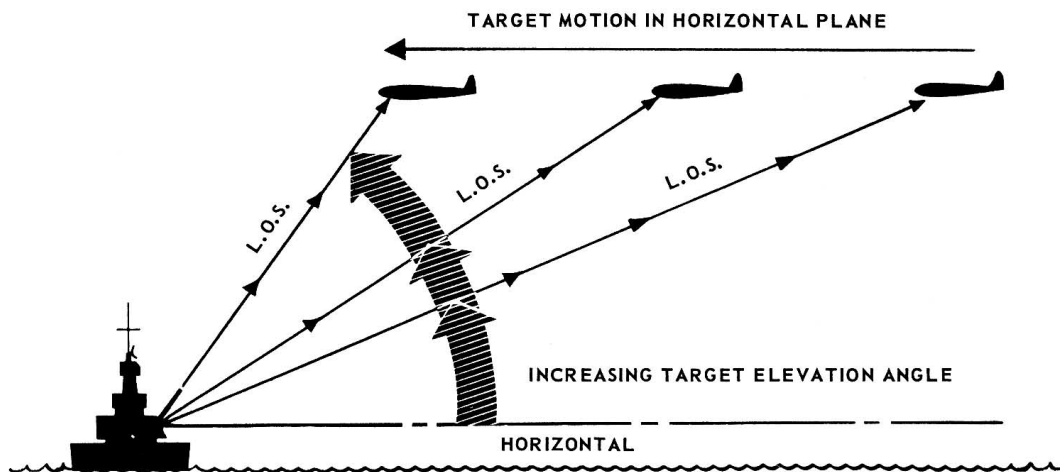

12.16

Figure 2-16.—Changing elevation angles for air target.

CHAPTER 2 - HITTING A MOVING TARGET FROM A MOVING SHIP

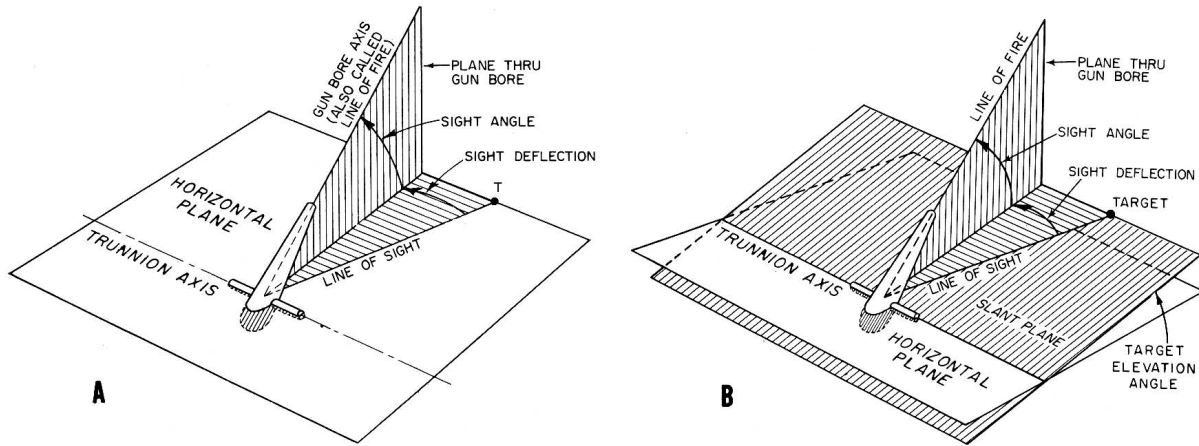

12.11.17

Figure 2-17.—Sight angle and sight deflection: A. In the surface problem; B. In the air problem.

between the gun and beam-rider missile problems is the target. Instead of pointing the launcher in the general direction of a physical target, we point it at a big radar beam. This beam is called the guidance beam. The missile is launched along a curved line (trajectory) which intercepts a point within the guidance beam called the capture point. Figure 2-18 illustrates the beam-rider fire control problem.

After the search radar has located the attacking aircraft, the tracking and guidance radar follows the aircraft with its beam. The missile follows or "rides" the beam to the target. The booster case drops off after booster burnout, and the missile continues onward.

Before the missile can follow the guidance beam, it must come within the area of the beam. that is, it must be captured by the beam in order

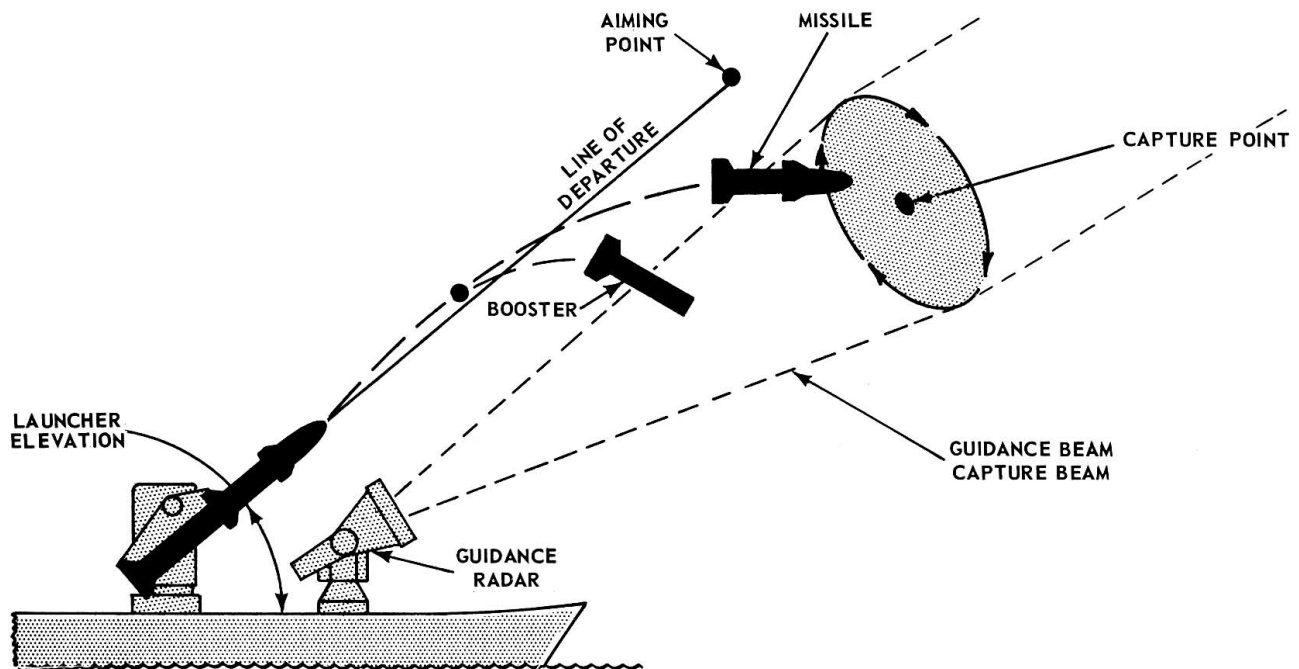

83.6

Figure 2-18.—Simplified beam-rider missile fire control problem — capture phase.

to be controlled by it. The missile must be aimed into the beam, not at the enemy aircraft in the distance, which may maneuver out of the way. In figure 2-18 you see that the "aiming point" is outside the beam, but that is because corrections for the effects on missile trajectory (air density, gravity, wind, etc.) will deflect the trajectory so the missile enters the radar beam and comes under its control.

You can visualize the guidance beam as a big circle several hundred yards wide with a small dot near the center. The dot symbolizes the capture point. In real life, of course, it is invisible. And so is the radar beam. If guided missile launchers had sights like guns have, you could look through them during missile launch and see only the sky. From an abstract and mathematical point of view, however, you would be looking at a point in space. Figure 2-18 shows this abstract point in more concrete form and it is labeled, simply, capture point. The fire control missile computer continuously figures out where the guidance beam and the capture point are. The computer determines the launcher train and elevation orders based on beam position and ballistic factors. These order are electrical signals which position the launcher. The missile is fired and if the lead angle is accurate, the missile hits the capture point and is captured by the beam. Once the beam has control of the missile, the missile is guided to a point high in the atmosphere. The missile rides the guidance beam until it intercepts the target (fig. 2-19).

While figure 2-19 shows the missile, flying straight to the target, in actual practice this is far from the case. The target is moving rapidly; the radar beam follows it, and the missile follows the beam. The target may change its course, and this may mean sharp changes in the course of the radar beam and the missile that rides it. A missile is subject to the same forces as a gun projectile while in flight. Corrections to the trajectory are calculated before the missile is fired, so it will have a correct start on its flight.

Lead angle is made up of two corrections- lead due to target motion, and lead due to ballistics. Assume that lead because of target motion is correct. If the missile is launched on a line pointed directly at the capture point, the missile will miss the capture point. Why? Because ballistic corrections have not been added to launcher train and elevation orders. These ballistic factors are (1) parallax, (2) gravity, and (3) wind deflection.

Parallax

Figure 2-20 shows what happens if the missile's trajectory is not corrected for parallax. The missile trajectory and guidance beam are offset, and the trajectory does not intercept the capture point. If we launched a missile under these conditions, the result would be a missile "by the deep-six." Like the gunfire control equipment, missile fire control equipment is spread out over the ship. The launcher and the guidance radar are physically offset along the centerline of the ship and also are at different heights above the deck of the ship. Therefore, if the launcher and radar are positioned at the same bearing and elevation angles, the line of fire of the launcher will be parallel to the guidance beam. As you know, the amount these parallel lines are offset from each other is called parallax. To compensate for parallax, the launcher bearing and elevation angles are offset toward the guidance beam. Then the launcher line of fire intersects the guidance beam, and the missile trajectory will intersect the capture point. Time to beam capture is very short, about 5 seconds after launch; booster burnout occurs about 1 sec second before this.

Gravity

In figure 2-21 you can see the effect of gravity on the missile's trajectory. For clarity, we have neglected the parallax and wind effects. Between launch and capture, gravity acts on the missile. At the instant when the missile should be captured by the guidance beam, it is actually some distance below the capture point. To compensate for the gravity effect, the launcher must be elevated so that the launcher line of fire intersects a point above the capture point. This is the same technique used in gunfire control to compensate for the effect of gravity. The name is the same too - superelevation correction.

Wind

Figure 2-22 illustrates the effects of wind on the missile trajectory. Once again, other effects are ignored. The wind tends to blow the missile off course during the period between launch and capture. Since the missile is not guided during this portion of its flight, wind corrections must be made before launch. The fire control computer calculates these corrections and sends them to the launcher. Therefore, the launcher is offset from the guidance radar line of sight

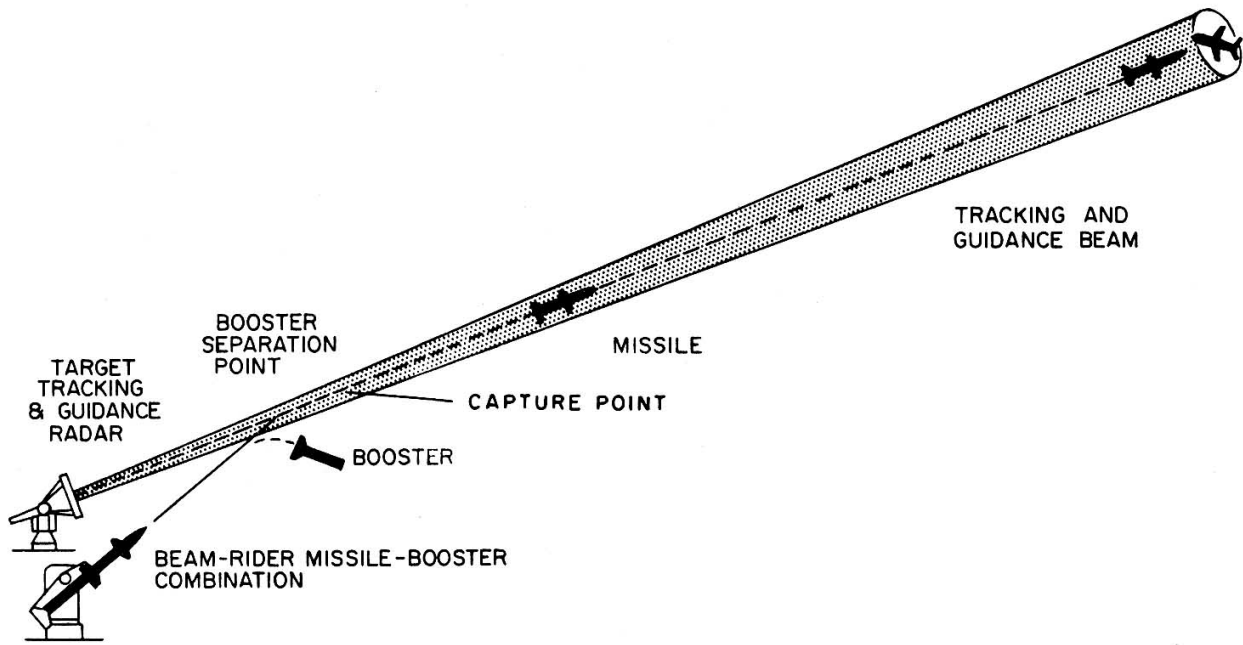

12.32

Figure 2-19.— Beam-rider missile follows the radar beam to the target.

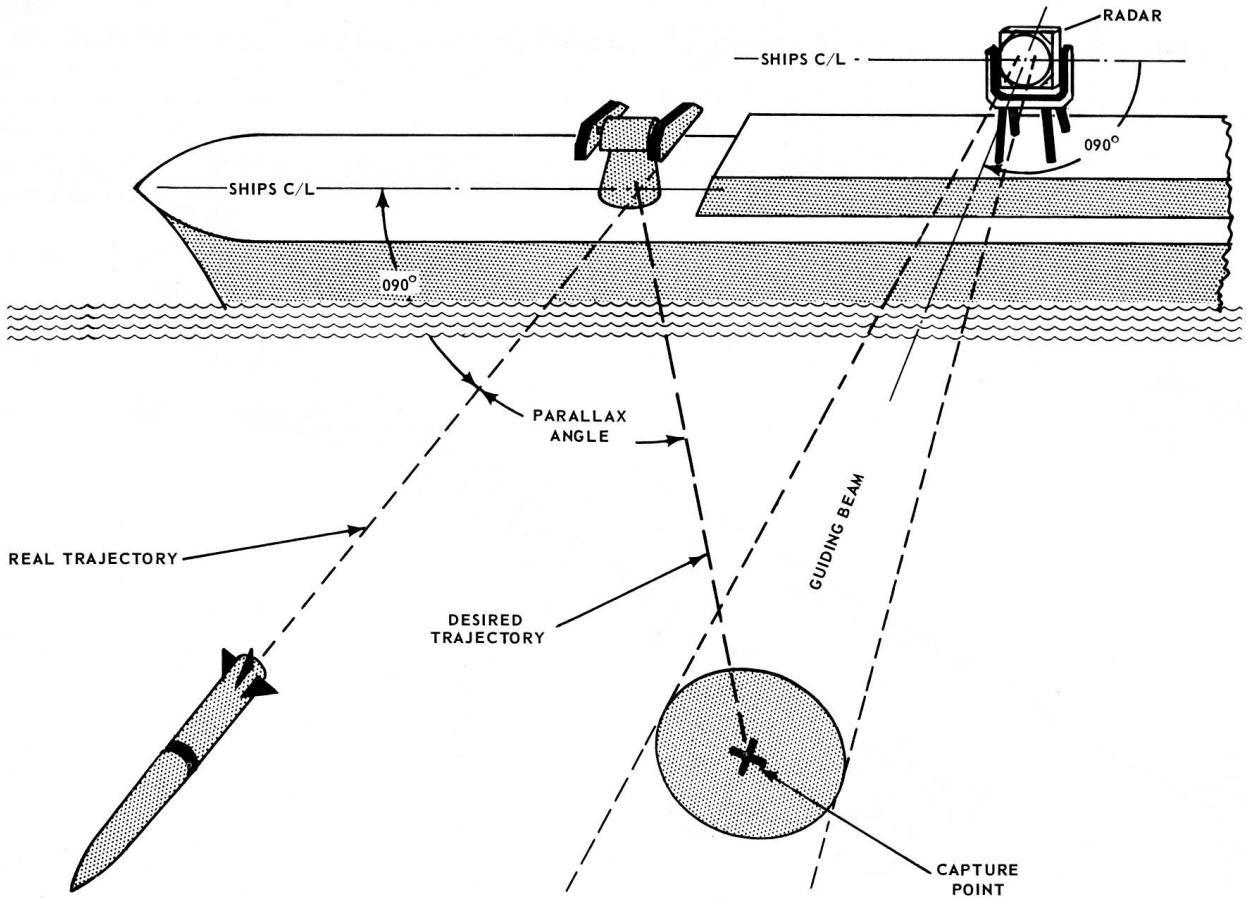

83.7

Figure 2-20.— Effect of parallax on a guided missile's trajectory (flight path) during boost.

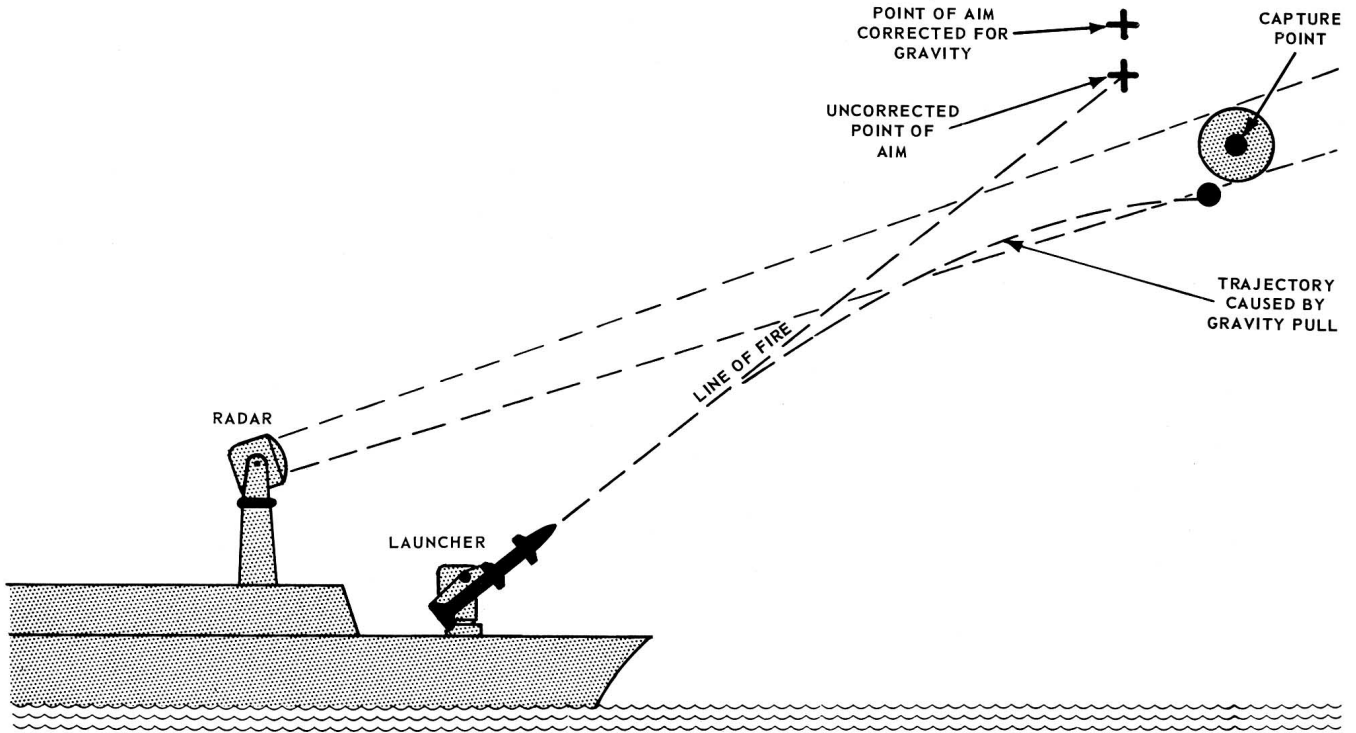

83.8

Figure 2-21.— The effect of gravity on a missile's flight path during the boost phase.

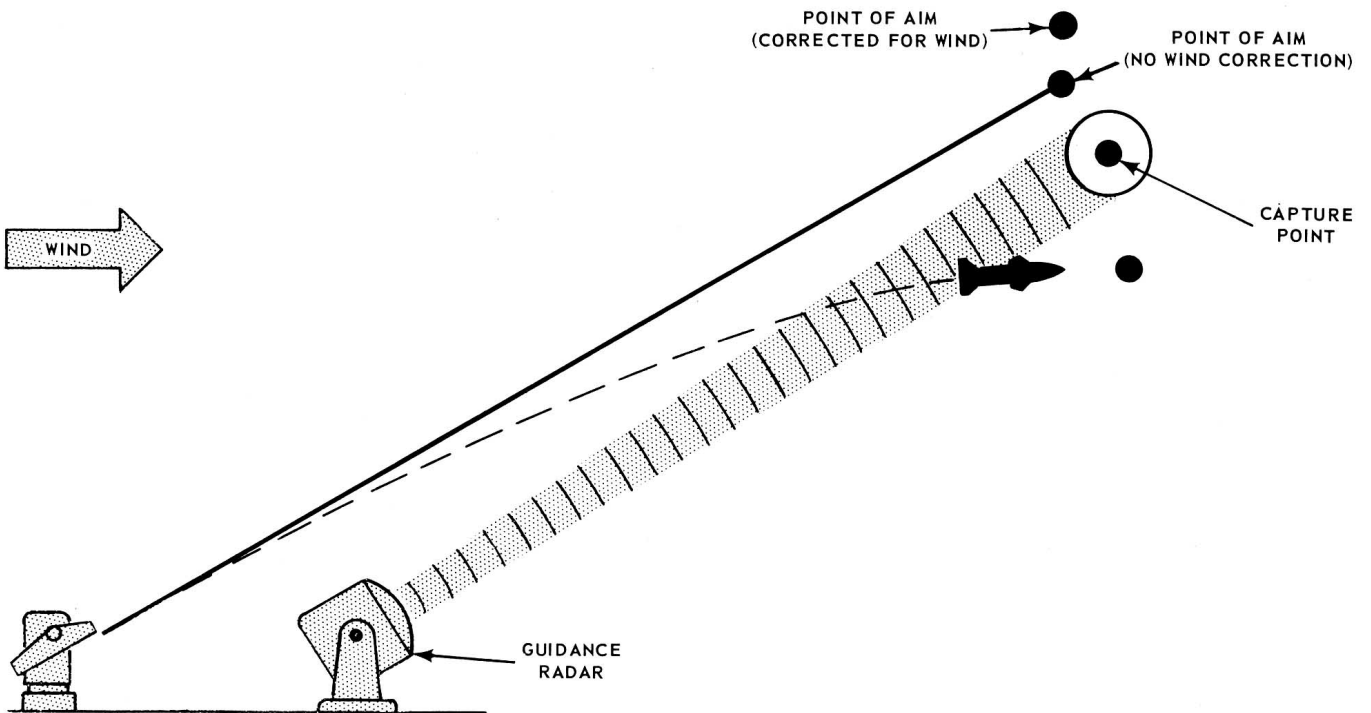

83.9

Figure 2-22.— Effect of wind on a guided missile's flight path.

CHAPTER 2 - HITTING A MOVING TARGET FROM A MOVING SHIP

by an amount proportional to the speed of the wind, and in a direction opposite to that of the wind. Now the wind will blow the missile into the guidance beam at the capture point.

The correction for wind includes not only true wind (atmospheric) speed and direction, but also apparent wind, caused by the ship's movement.

SUMMARY

This chapter has briefly covered some of the more important aspects of the surface and air fire control problems. You have seen that the correct solution of a fire control problem depends on many factors. First of all, the target must be detected and tracked. Detection and tracking require an equipment such as radar, which will continuously and automatically provide target bearings and ranges. In the air problem, it must also provide continuous information regarding the elevation angles of the target. This information must be automatically transmitted to a fire control computer, which will compare it with own ship's motion as measured by gyrocompass and pitometer log. In addition, the computer also takes into consideration such factors as level and crosslevel information from the stable element, superelevation, trunnion tilt, wind speed and direction,

parallax, in some cases Coriolis effect, air density, and powder temperature (in missile FC computers). The resulting gun and missile orders are continuously generated by the computer and are electrically transmitted to the gun (or launcher) train and elevation power drives, thus causing the line of fire to lead the line of sight by the proper amounts in bearing and elevation. There are many more details of computation in the solution of the fire control problem for guns and missiles, but these are not covered in this text.

Later chapters of this training course will show you in greater detail how a modern weapons system operates. The next chapter will discuss the flight principles and propulsion units of guided missiles.

You may be asked yourself, "Why should I learn more about fire control?" One answer to that question might be: You'll be able to see how important your job is.

The quals for your job require you to know the basic principles of missile flight control, ballistics, and fire control variables. The same forces of nature (wind, air density, gravity, etc.) that affect projectile flight also affect missile flight. The man made thrust force has some variations from guns to missiles, but the principles are the same. As you advance, you must learn how various components function in fire control. The same types of components were used for gun fire control before missiles were invented.